

Bangladesh BM Energy's PDH- PP Chemical Plant 150KTA

Description	Values	Unit
Work Start Year	2018	Years
Operating Year	2021	Years
Site and Contry for Project	Bangladesh	
Sensitivity of Golobal Financial Crisis	0	Years- Active Crisis Year, Otherwise = 0
Propane Desity(kg/m³)	493	Gas 2.0098kg/m³ at 0 °C, 101.3 kPa, Liquid for 493kg/m³ at 25°C and Liquid for 504kg/m³ at 15.6°C
Required Homo-Polymer	150	KTA(Killo-Ton/Annual)
Homopolymer Density(kg/m³)	904	kg/m³(904-908)
Polymer Unit Rate from Unit volume of Propane	0.4001	ton/m³
	105.177639	Lb/bbl
Required Propane Volume per year	374,909	m³/year
	3,144,089	bbl/year
Required Propane Weight per year	184,830,000	kg/year
	407,480,399	Lb/year
Propane Transportation Unit Cost	0.5	USD/tonday(30,000~38,000DWT)
LPG Carrier Speed	18	Knots
Transportation Distance	10000	km
Transportation Period	29	Day Transportation
Initial Inflation of propane Price	0	%
Purchase Unit feedstock (propane)	0.7077	US\$/gallon for Propane
	0.3792	US\$/kg for Propane
	0.1720	US\$/Lb for Propane
Transportation Cost	2,679,850	US\$/year
Logistics Unit costs / netbacks	0.2205	US\$/kg for PP
	0.1000	US\$/Lb for PP
Export Unit fuel balance	0.0313	US\$/kg for PP
	0.0142	US\$/Lb for PP
Variable cost of PP unit (including inter-plant handling costs for propylene)	0.0586	US\$/kg for PP
	0.0266	US\$/Lb for PP
PP Unit Sale Price	1.0364	US\$/kg for PP
	0.4701	US\$/Lb for PP
Purchase Cost of feedstock (propane) per year	72,771,797	USD/year(including transportation)
Cost of PP Handling,Logistics Fuel and Others	46,561,630	USD/year
Total Sale Cos of PP	155,452,500	USD/year
Unit Land Size per 1KTA	333	m²/KTA
Total Land Size	50,000	m²
Unit Space Acquisition Cost	10	USD/m² in Bangladesh
CAPEX of Area Acquisition Cost	500,000	USD
Unit CAPEX of Chemical Plant	1,763	USD/tonne/year(1,322~1,763)
Uni OPEX of Chemical Plant	52.89	USD/tonne/year
CAPEX for PDH-PP Chemical Plant	264,950,000	USD - 이익육천사백구십오만달러
Construction and Fabrication Period	3	Years
Interest FEE during Construction and Fabrication	19,871,250	USD
TOTAL CAPEX AND INSTREST FEE DURING CONSTRUCTION	284,821,250	USD - 이익팔천사백팔십이만일천이백오
Toal OPEX	7,933,500	USD/year
Fund Instrest	5	%
Return rate on investment of Net Profit, r	1	%
Operating Periods	25	Years
Project Design Life	50	Years
Benefit Cost Ratio (B/C)	1.27	≥ 1.1 GOOD For 25Years Operating

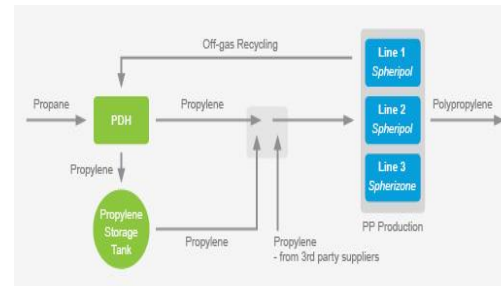
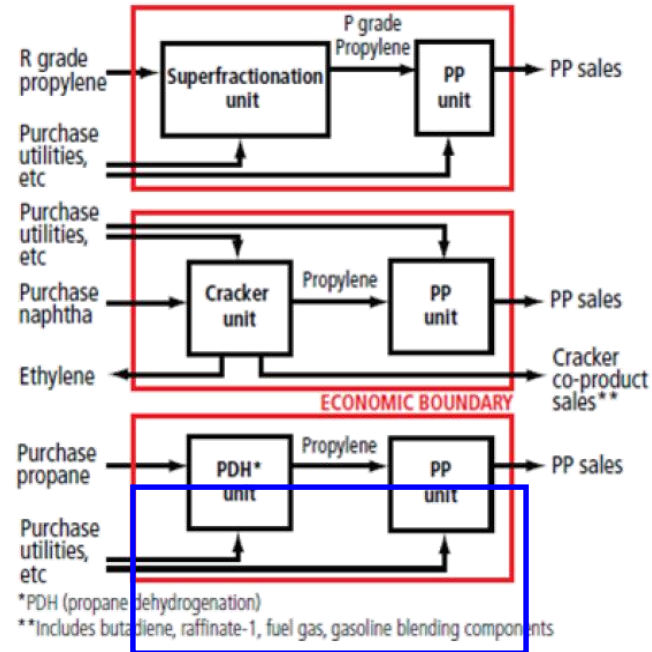

IRR(Internal Rate of Return)	12.80%	> 0 GOOD For 25Years Operating
NPV(Net Present Value)	918,061,808	USD with Asset value of Project for 25Ye
Inflation of LPG Purchased Price	0	%, If Inflation = 0, the Propane Unit price shall be quoted Forecast Price, otherwise consider inflation based on 2021Years Sale Cost, If no consider Inflation, the value=10E-11
1. Sale Cost of PP is applicable Based on inflation of Propane Forecast Price	1	<= 0 : Not Applicable, 1 : Applicable of Propane Forecast Price
2. PP Sale Price	from 2021Years to 2023 Years	0 % from 1Years to 3 Years
Inflation to be considered in yeras(Increased Previous Inflation)	from 2024Years to 2027 Years from 2028Years to 2030 Years from 2031Years to 2035 Years from 2036Years to 2045 Years	0 % from 4Years to 7 Years 0 % from 8Years to 10 Years 0 % from 11Years to 15 Years 0 % from 16Years to 25 Years
Income tax rate for government	10	%
Inflation of Space Acquisition	1	%
First Project residual value	167,420,261	USD after 10 Years
Second Project residual value	67,050,874	USD after 30 Years
Final residual value on Design Life	27,267,316	USD after 50 Years
Net Payback Turn Over Periods	9.009	Years

The model assumes 1.22 lb of propane are required to produce 1 lb of propylene and 1.01 lb of propylene are required to produce 1 lb of PP

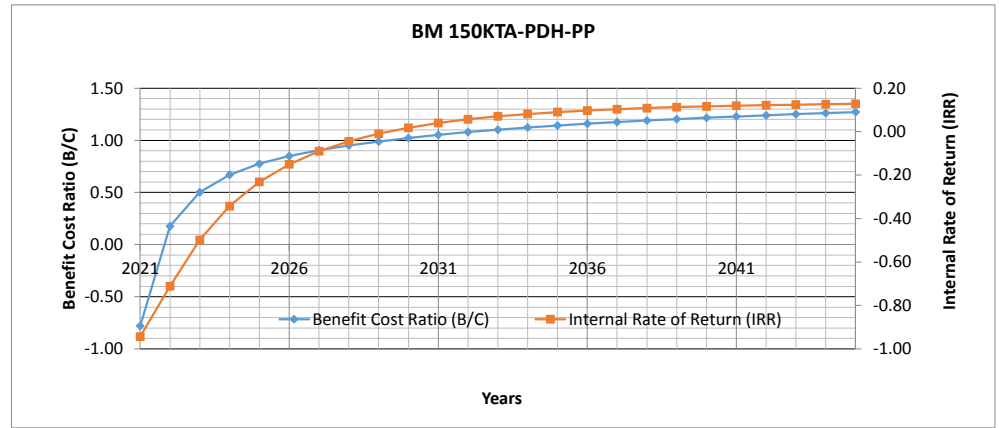

Actual Payback turn Over Years	10Years	10Years	해찾기
Initial Value(min 0%, max 10%)	4.431%	4.431%	0 Good
Limit of Initial Value	≤ 10%	≤ 10%	

End of Year	%	Return of Equity (USD)	Return of FUND(USD)	Remain Cost(USD)	Fund Interest 5%(USD)	OPEX(USD)	Yearly Revenue(USD)	Yearly Purchased Price(USD) of Propane W/ Inflation	Net Profit(USD)	(현재자산가치)Asset value=Residual Value(USD)	(순현재가치)Net Present Value	Benefit Cost Ratio (B/C)	(내부수익률)Internal Rate of Return (IRR)		
														% of Return of Equity	% of Return of FUND
2021	1	4.43%	4.43%	2,524,177	10,096,707	264,950,000	13,247,500	7,933,500	155,452,500	119,333,427	2,085,471	253,100,029	-247,682,999	-0.78	-0.94
2022	2	5.67%	5.67%	3,229,121	12,916,483	252,329,117	12,616,456	7,933,500	159,438,462	121,130,656	1,451,021	241,688,450	-230,447,405	0.18	-0.71
2023	3	6.91%	6.91%	3,934,065	15,736,259	236,183,513	11,809,176	7,933,500	163,424,423	122,927,886	975,184	230,851,101	-210,503,352	0.50	-0.50
2024	4	8.14%	8.14%	4,639,009	18,556,036	216,513,189	10,825,659	7,933,500	167,410,385	124,725,115	657,959	220,542,702	-187,738,479	0.67	-0.34
2025	5	9.38%	9.38%	5,343,953	21,375,812	193,318,144	9,665,907	7,933,500	171,396,346	126,522,345	499,347	210,763,255	-162,044,577	0.78	-0.23
2026	6	10.62%	10.62%	6,048,897	24,195,588	166,598,380	8,329,919	7,933,500	175,382,308	128,319,574	499,347	201,248,310	-133,317,500	0.85	-0.15
2027	7	11.86%	11.86%	6,753,841	27,015,364	136,353,894	6,817,695	7,933,500	179,368,269	130,116,803	657,959	192,262,318	-101,457,079	0.91	-0.09
2028	8	13.09%	13.09%	7,458,785	29,835,141	102,584,689	5,129,234	7,933,500	183,354,231	131,914,033	975,184	183,540,828	-66,367,035	0.95	-0.04
2029	9	14.33%	14.33%	8,163,729	32,654,917	65,290,763	3,264,538	7,933,500	187,340,192	133,711,262	1,451,021	175,348,293	-27,954,902	0.99	-0.01
2030	10	15.57%	15.57%	8,868,673	35,474,693	24,472,117	1,223,606	7,933,500	191,326,154	135,508,492	2,085,471	167,420,261	-13,868,061	1.02	0.02
2031	11	0.00%	0.00%	0	0	-19,871,250	-993,563	7,933,500	195,312,115	137,305,721	45,959,811	160,021,184	59,186,949	1.05	0.04
2032	12	0.00%	0.00%	0	0	-19,871,250	-993,563	7,933,500	199,298,077	139,102,950	47,929,670	152,886,613	105,980,291	1.08	0.06
2033	13	0.00%	0.00%	0	0	-19,871,250	-993,563	7,933,500	203,284,038	140,900,180	49,899,529	146,016,547	154,214,450	1.10	0.07
2034	14	0.00%	0.00%	0	0	-19,871,250	-993,563	7,933,500	207,270,000	142,697,409	51,869,388	139,410,987	203,856,305	1.12	0.08
2035	15	0.00%	0.00%	0	0	-19,871,250	-993,563	7,933,500	211,255,962	144,494,639	53,839,247	133,069,934	254,873,255	1.14	0.09
2036	16	0.00%	0.00%	0	0	-19,871,250	-993,563	7,933,500	215,241,923	146,291,868	55,809,106	127,257,839	307,233,202	1.16	0.10
2037	17	0.00%	0.00%	0	0	-19,871,250	-993,563	7,933,500	219,227,885	148,089,097	57,778,965	121,710,252	360,904,552	1.18	0.10
2038	18	0.00%	0.00%	0	0	-19,871,250	-993,563	7,933,500	223,213,846	149,886,327	59,748,824	116,162,724	415,856,203	1.19	0.11
2039	19	0.00%	0.00%	0	0	-19,871,250	-993,563	7,933,500	227,199,808	151,683,556	61,718,683	110,879,704	472,057,542	1.20	0.11
2040	20	0.00%	0.00%	0	0	-19,871,250	-993,563	7,933,500	231,185,769	153,480,786	63,688,541	105,861,195	529,478,435	1.22	0.12
2041	21	0.00%	0.00%	0	0	-19,871,250	-993,563	7,933,500	235,171,731	155,278,015	65,658,400	101,107,196	588,089,224	1.23	0.12
2042	22	0.00%	0.00%	0	0	-19,871,250	-993,563	7,933,500	239,157,692	157,075,244	67,628,259	96,617,708	647,860,717	1.24	0.12
2043	23	0.00%	0.00%	0	0	-19,871,250	-993,563	7,933,500	243,143,654	158,872,474	69,598,118	92,392,732	708,764,184	1.25	0.12
2044	24	0.00%	0.00%	0	0	-19,871,250	-993,563	7,933,500	247,129,615	160,669,703	71,567,977	88,167,817	770,771,351	1.26	0.13
2045	25	0.00%	0.00%	0	0	-19,871,250	-993,563	7,933,500	251,115,577	162,466,933	73,537,836	84,207,416	833,854,392	1.27	0.13

2046	26	0.00%	0.00%	0	0	-19,871,250	-993,563	0	0	0	0	0	0	0.00	0.00
2047	27	0.00%	0.00%	0	0	-19,871,250	-993,563	0	0	0	0	0	0	0.00	0.00
2048	28	0.00%	0.00%	0	0	-19,871,250	-993,563	0	0	0	0	0	0	0.00	0.00
2049	29	0.00%	0.00%	0	0	-19,871,250	-993,563	0	0	0	0	0	0	0.00	0.00
2050	30	0.00%	0.00%	0	0	-19,871,250	-993,563	0	0	0	0	0	0	0.00	0.00
2051	31	0.00%	0.00%	0	0	-19,871,250	-993,563	0	0	0	0	0	0	0.00	0.00
2052	32	0.00%	0.00%	0	0	-19,871,250	-993,563	0	0	0	0	0	0	0.00	0.00
2053	33	0.00%	0.00%	0	0	-19,871,250	-993,563	0	0	0	0	0	0	0.00	0.00
2054	34	0.00%	0.00%	0	0	-19,871,250	-993,563	0	0	0	0	0	0	0.00	0.00
2055	35	0.00%	0.00%	0	0	-19,871,250	-993,563	0	0	0	0	0	0	0.00	0.00
2056	36	0.00%	0.00%	0	0	-19,871,250	-993,563	0	0	0	0	0	0	0.00	0.00
2057	37	0.00%	0.00%	0	0	-19,871,250	-993,563	0	0	0	0	0	0	0.00	0.00
2058	38	0.00%	0.00%	0	0	-19,871,250	-993,563	0	0	0	0	0	0	0.00	0.00
2059	39	0.00%	0.00%	0	0	-19,871,250	-993,563	0	0	0	0	0	0	0.00	0.00
2060	40	0.00%	0.00%	0	0	-19,871,250	-993,563	0	0	0	0	0	0	0.00	0.00
2061	41	0.00%	0.00%	0	0	-19,871,250	-993,563	0	0	0	0	0	0	0.00	0.00
2062	42	0.00%	0.00%	0	0	-19,871,250	-993,563	0	0	0	0	0	0	0.00	0.00
2063	43	0.00%	0.00%	0	0	-19,871,250	-993,563	0	0	0	0	0	0	0.00	0.00
2064	44	0.00%	0.00%	0	0	-19,871,250	-993,563	0	0	0	0	0	0	0.00	0.00
2065	45	0.00%	0.00%	0	0	-19,871,250	-993,563	0	0	0	0	0	0	0.00	0.00
2066	46	0.00%	0.00%	0	0	-19,871,250	-993,563	0	0	0	0	0	0	0.00	0.00
2067	47	0.00%	0.00%	0	0	-19,871,250	-993,563	0	0	0	0	0	0	0.00	0.00
2068	48	0.00%	0.00%	0	0	-19,871,250	-993,563	0	0	0	0	0	0	0.00	0.00
2069	49	0.00%	0.00%	0	0	-19,871,250	-993,563	0	0	0	0	0	0	0.00	0.00
2070	50	0.00%	0.00%	0	0	-19,871,250	-993,563	0	0	0	0	0	0	0.00	0.00
	Summation	100%	100%	56,964,250	227,857,000	863,743,806	43,187,190	198,337,500	5,082,100,962	3,522,504,495	907,570,318	84,207,416	918,061,808	1.27	0.13

1. ICIS, POLYETHYLENE US MARGIN REPORT, ICIS Weekly Margin - POLYETHYLENE (PE) US Methodology, pp.3

2. ICIS, ICIS Weekly Margin – PP US report. POLYPROPYLENE US MARGIN REPORT, pp.2 to pp.4

3. A M Saravanan, Khalid Ali Sulaiman, 2014, A Study on the Process Plant Design for Production of Polypropylene Plant, International Journal of Emerging Technology and Advanced Engineering, pp.633

4. James G. Speight, 2002, CHEMICAL AND PROCESS DESIGN HANDBOOK, ISBN 0-07-137433-7, pp. 1.41 to pp.1.42 and pp.2.434 to pp. 2.437

PFD FOR PDH-PP CHEMICAL PLANT

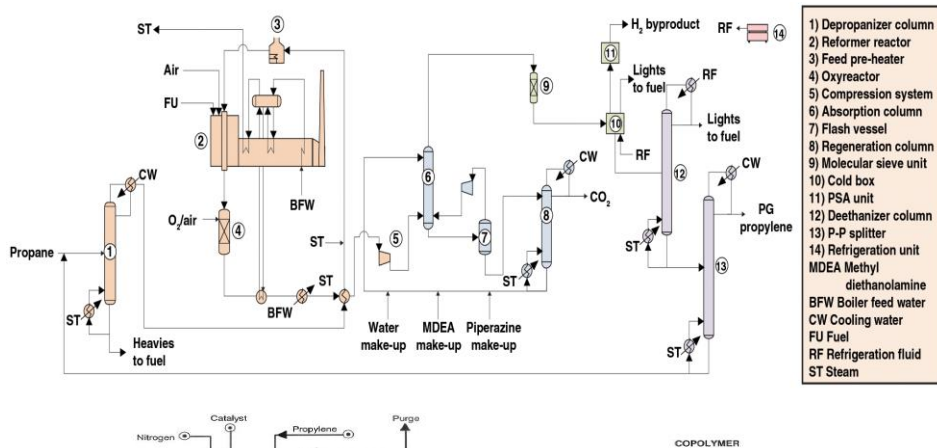

PFD FOR PDH

PFD FOR PP

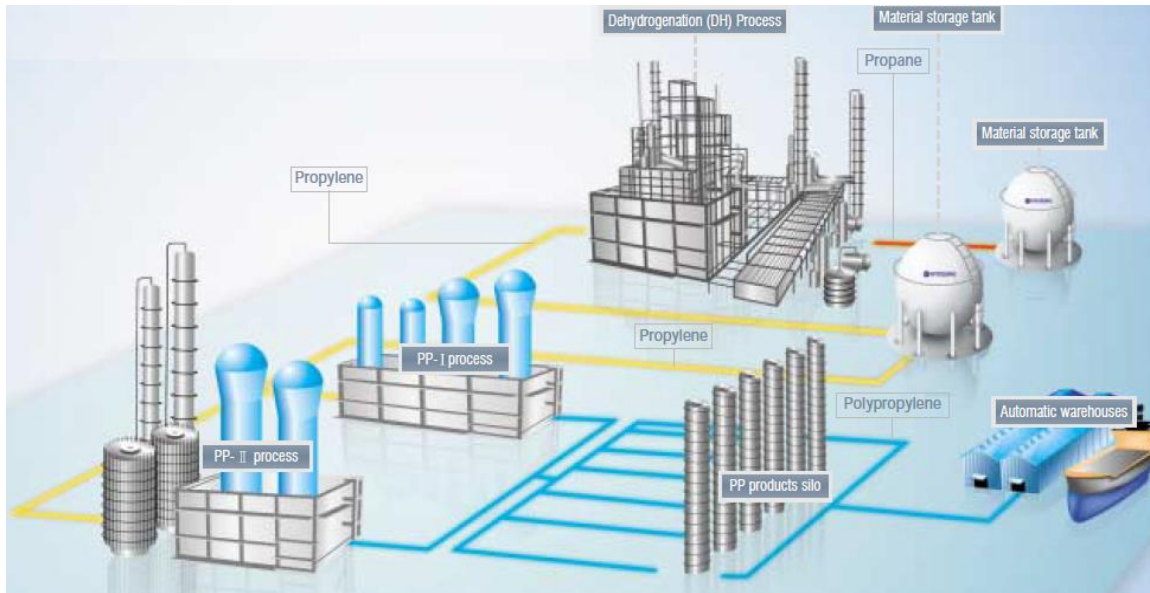
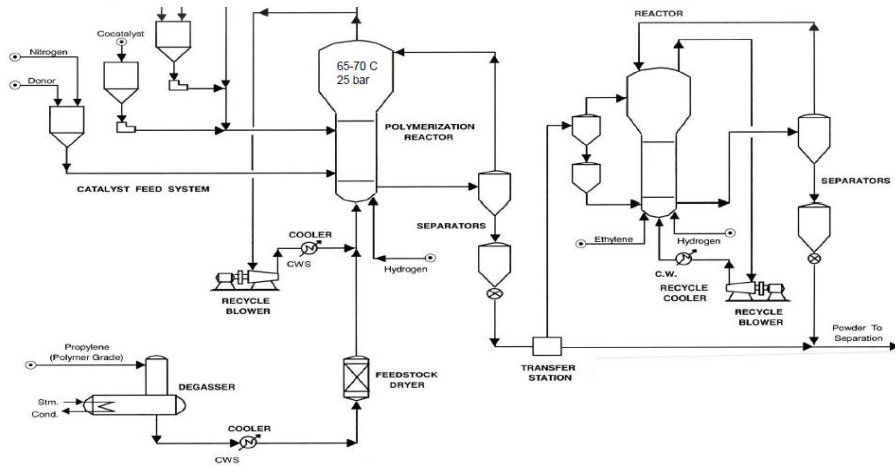

Bangladesh BM Energy's PDH- PP Chemical Plant 300KTA

Description	Values	Unit
Work Start Year	2018	Years
Operating Year	2021	Years
Site and Contry for Project	Bangladesh	
Sensitivity of Golobal Financial Crisis	0	Years- Active Crisis Year, Otherwise = 0
Propane Desity(kg/m³)	493	Gas 2.0098kg/m³ at 0 °C, 101.3 kPa, Liquid for 493kg/m³ at 25°C and Liquid for 504kg/m³ at 15.6°C
Required Homo-Polymer	300	KTA(Killo-Ton/Annual)
Homopolymer Density(kg/m³)	904	kg/m³(904-908)
Polymer Unit Rate from Unit volume of Propane	0.4001	ton/m³
	105.177639	Lb/bbl
Required Propane Volume per year	749,817	m³/year
	6,288,177	bbl/year
Required Propane Weight per year	369,660,000	kg/year
	814,960,798	Lb/year
Propane Transportation Unit Cost	0.5	USD/tonday(30,000~38,000DWT)
LPG Carrier Speed	18	Knots
Transportation Distance	10000	km
Transportation Period	29	Days
Initial Inflation of propane Price	0	%
Purchase Unit feedstock (propane)	0.7077	US\$/gallon for Propane
	0.3792	US\$/kg for Propane
	0.1720	US\$/Lb for Propane
Transportation Cost	5,359,700	US\$/year
Logistics Unit costs / netbacks	0.2205	US\$/kg for PP
	0.1000	US\$/Lb for PP
Export Unit fuel balance	0.0313	US\$/kg for PP
	0.0142	US\$/Lb for PP
Variable cost of PP unit (including inter-plant handling costs for propylene)	0.0586	US\$/kg for PP
	0.0266	US\$/Lb for PP
PP Unit Sale Price	1.0364	US\$/kg for PP
	0.4701	US\$/Lb for PP
Purchase Cost of feedstock (propane) per year	145,543,594	USD/year(including transportation)
Cost of PP Handling,Logistics Fuel and Others	93,123,260	USD/year
Total Sale Cos of PP	310,905,000	USD/year
Unit Land Size per 1KTA	333	m²/KTA
Total Land Size	100,000	m²
Unit Space Acquisition Cost	10	USD/m² in Bangladesh
CAPEX of Area Acquisition Cost	1,000,000	USD
Unit CAPEX of Chemical Plant	1,763	USD/tonne/year(1,322~1,763)
Uni OPEX of Chemical Plant	52.89	USD/tonne/year
CAPEX for PDH-PP Chemical Plant	529,900,000	USD - 오역이전구백육십만달러
Construction and Fabrication Period	3	Years
Interest FEE during Construction and Fabrication	39,742,500	USD
TOTAL CAPEX AND INSTREST FEE DURING CONSTRUCTION	569,642,500	USD - 오역육천구백육십사만이천오백달러
Toal OPEX	15,867,000	USD/year
Fund Instrest	5	%
Return rate on investment of Net Profit, r	1	%
Operating Periods	25	Years
Project Design Life	50	Years
Benefit Cost Ratio (B/C)	1.27	≥ 1.1 GOOD For 25Years Operating

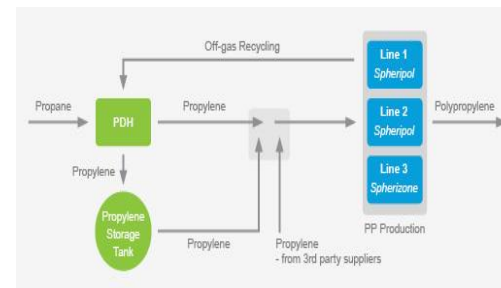
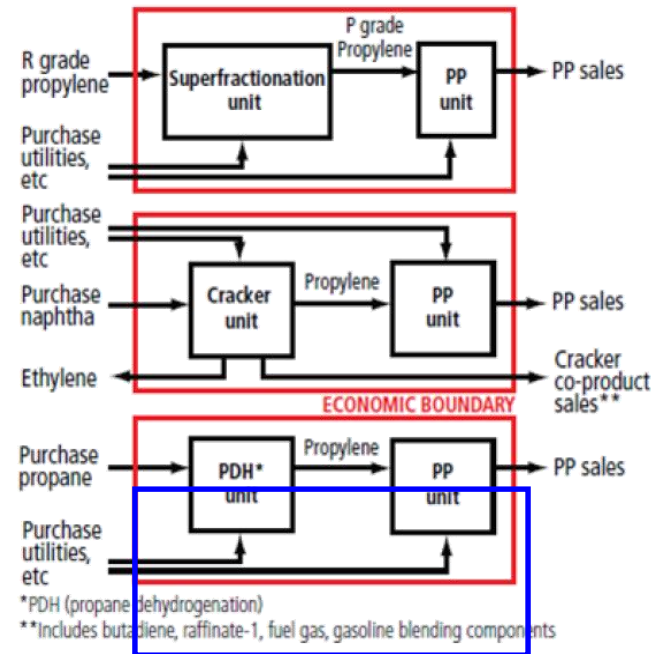

IRR(Internal Rate of Return)	12.80%	> 0 GOOD For 25Years Operating
NPV(Net Present Value)	1,836,123,615	USD with Asset value of Project for 25Ye
Inflation of LPG Purchased Price	0	%, If Inflation = 0, the Propane Unit price shall be quoted Forecast Price, otherwise consider inflation based on 2021Years Sale Cost, If no consider Inflation, the value=10E-11
1. Sale Cost of PP is applicable Based on inflation of Propane Forecast Price	1	<-- 0 : Not Applicable, 1 : Applicable of Propane Forecast Price
2. PP Sale Price	from 2021Years to 2023 Years	0 % from 1Years to 3 Years
Inflation to be considered in	from 2024Years to 2027 Years	0 % from 4Years to 7 Years
years(Increased	from 2028Years to 2030 Years	0 % from 8Years to 10 Years
Previous Inflation)	from 2031Years to 2035 Years	0 % from 11Years to 15 Years
	from 2036Years to 2045 Years	0 % from 16Years to 25 Years
Income tax rate for government	10	%
Inflation of Space Acquisition	1	%
First Project residual value	334,840,522	USD after 10 Years
Second Project residual value	134,101,749	USD after 30 Years
Final residual value on Design Life	54,534,632	USD after 50 Years
Net Payback Turn Over Periods	9.009	Years

The model assumes 1.22 lb of propane are required to produce 1 lb of propylene and 1.01 lb of propylene are required to produce 1 lb of PP

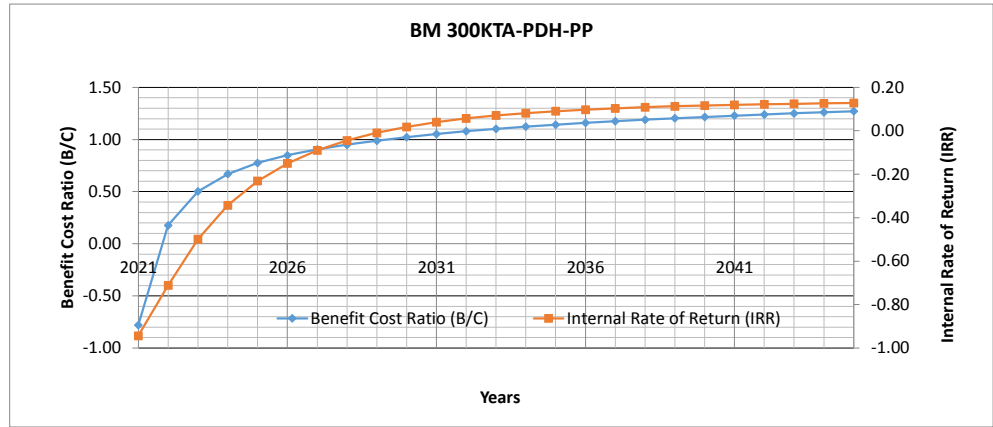

Actual Payback turn Over Years	10Years	10Years	해 찾기
Initial Value(min 0%, max 10%)	4.431%	4.431%	0
Limit of Initial Value	≤ 10%	≤ 10%	Good

End of Year	%	Return of Equity (USD)	Return of FUND(USD)	Remain Cost(USD)	Fund Interest 5%(USD)	OPEX(USD)	Yearly Revenue(USD)	Yearly Purchased Price(USD) of Propane W/ Inflation	Net Profit(USD)	(현재자산가치)Asset value=Residual Value(USD)	(순현재가치)Net Present Value	Benefit Cost Ratio (B/C)	(내부수익률)Internal Rate of Return (IRR)		
														% of Return of Equity	% of Return of FUND
2021	1	4.43%	4.43%	5,048,353	20,193,413	529,900,000	26,495,000	15,867,000	310,905,000	238,666,854	4,170,942	506,200,058	-495,365,997	-0.78	-0.94
2022	2	5.67%	5.67%	6,458,241	25,832,966	504,658,233	25,232,912	15,867,000	318,876,923	242,261,313	2,902,042	483,376,900	-460,894,810	0.18	-0.71
2023	3	6.91%	6.91%	7,868,130	31,472,519	472,367,026	23,618,351	15,867,000	326,848,846	245,855,771	1,950,368	461,702,201	-421,006,704	0.50	-0.50
2024	4	8.14%	8.14%	9,278,018	37,112,071	433,026,378	21,651,319	15,867,000	334,820,769	249,450,230	1,315,918	441,085,404	-375,476,958	0.67	-0.34
2025	5	9.38%	9.38%	10,687,906	42,751,624	386,636,289	19,331,814	15,867,000	342,792,692	253,044,689	998,693	421,526,510	-324,089,155	0.78	-0.23
2026	6	10.62%	10.62%	12,097,794	48,391,176	333,196,759	16,659,838	15,867,000	350,764,615	256,639,148	998,693	402,496,620	-266,635,001	0.85	-0.15
2027	7	11.86%	11.86%	13,507,682	54,030,729	272,707,789	13,635,389	15,867,000	358,736,538	260,233,607	1,315,918	384,524,635	-202,914,157	0.91	-0.09
2028	8	13.09%	13.09%	14,917,570	59,670,281	205,169,378	10,258,469	15,867,000	366,708,462	263,828,066	1,950,368	367,081,657	-132,734,071	0.95	-0.04
2029	9	14.33%	14.33%	16,327,459	65,309,834	130,581,526	6,529,076	15,867,000	374,680,385	267,422,524	2,902,042	350,696,585	-55,909,805	0.99	-0.01
2030	10	15.57%	15.57%	17,737,347	70,949,387	48,944,233	2,447,212	15,867,000	382,652,308	271,016,983	4,170,942	334,840,522	-27,736,122	1.02	0.02
2031	11	0.00%	0.00%	0	0	-39,742,500	-1,987,125	15,867,000	390,624,231	274,611,442	91,919,622	320,042,368	118,373,897	1.05	0.04
2032	12	0.00%	0.00%	0	0	-39,742,500	-1,987,125	15,867,000	398,596,154	278,205,901	95,859,340	305,773,225	211,960,583	1.08	0.06
2033	13	0.00%	0.00%	0	0	-39,742,500	-1,987,125	15,867,000	406,568,077	281,800,360	99,799,058	292,033,093	308,428,899	1.10	0.07
2034	14	0.00%	0.00%	0	0	-39,742,500	-1,987,125	15,867,000	414,540,000	285,394,818	103,738,776	278,821,974	407,712,611	1.12	0.08
2035	15	0.00%	0.00%	0	0	-39,742,500	-1,987,125	15,867,000	422,511,923	288,989,277	107,678,494	266,139,869	509,746,510	1.14	0.09
2036	16	0.00%	0.00%	0	0	-39,742,500	-1,987,125	15,867,000	430,483,846	292,583,736	111,618,212	254,515,679	614,466,404	1.16	0.10
2037	17	0.00%	0.00%	0	0	-39,742,500	-1,987,125	15,867,000	438,455,769	296,178,195	115,557,929	243,420,504	721,809,104	1.18	0.10
2038	18	0.00%	0.00%	0	0	-39,742,500	-1,987,125	15,867,000	446,427,692	299,772,654	119,497,647	232,325,447	831,712,407	1.19	0.11
2039	19	0.00%	0.00%	0	0	-39,742,500	-1,987,125	15,867,000	454,399,615	303,367,112	123,437,365	221,759,409	944,115,084	1.20	0.11
2040	20	0.00%	0.00%	0	0	-39,742,500	-1,987,125	15,867,000	462,371,538	306,961,571	127,377,083	211,722,390	1,058,956,871	1.22	0.12
2041	21	0.00%	0.00%	0	0	-39,742,500	-1,987,125	15,867,000	470,343,462	310,556,030	131,316,801	202,214,392	1,176,178,448	1.23	0.12
2042	22	0.00%	0.00%	0	0	-39,742,500	-1,987,125	15,867,000	478,315,385	314,150,489	135,256,519	193,235,416	1,295,721,434	1.24	0.12
2043	23	0.00%	0.00%	0	0	-39,742,500	-1,987,125	15,867,000	486,287,308	317,744,948	139,196,236	184,785,463	1,417,528,368	1.25	0.12
2044	24	0.00%	0.00%	0	0	-39,742,500	-1,987,125	15,867,000	494,259,231	321,339,407	143,135,954	176,335,635	1,541,542,702	1.26	0.13
2045	25	0.00%	0.00%	0	0	-39,742,500	-1,987,125	15,867,000	502,231,154	324,933,865	147,075,672	168,414,832	1,667,708,783	1.27	0.13

2046	26	0.00%	0.00%	0	0	-39,742,500	-1,987,125	0	0	0	0	0	0	0.00	0.00
2047	27	0.00%	0.00%	0	0	-39,742,500	-1,987,125	0	0	0	0	0	0	0.00	0.00
2048	28	0.00%	0.00%	0	0	-39,742,500	-1,987,125	0	0	0	0	0	0	0.00	0.00
2049	29	0.00%	0.00%	0	0	-39,742,500	-1,987,125	0	0	0	0	0	0	0.00	0.00
2050	30	0.00%	0.00%	0	0	-39,742,500	-1,987,125	0	0	0	0	0	0	0.00	0.00
2051	31	0.00%	0.00%	0	0	-39,742,500	-1,987,125	0	0	0	0	0	0	0.00	0.00
2052	32	0.00%	0.00%	0	0	-39,742,500	-1,987,125	0	0	0	0	0	0	0.00	0.00
2053	33	0.00%	0.00%	0	0	-39,742,500	-1,987,125	0	0	0	0	0	0	0.00	0.00
2054	34	0.00%	0.00%	0	0	-39,742,500	-1,987,125	0	0	0	0	0	0	0.00	0.00
2055	35	0.00%	0.00%	0	0	-39,742,500	-1,987,125	0	0	0	0	0	0	0.00	0.00
2056	36	0.00%	0.00%	0	0	-39,742,500	-1,987,125	0	0	0	0	0	0	0.00	0.00
2057	37	0.00%	0.00%	0	0	-39,742,500	-1,987,125	0	0	0	0	0	0	0.00	0.00
2058	38	0.00%	0.00%	0	0	-39,742,500	-1,987,125	0	0	0	0	0	0	0.00	0.00
2059	39	0.00%	0.00%	0	0	-39,742,500	-1,987,125	0	0	0	0	0	0	0.00	0.00
2060	40	0.00%	0.00%	0	0	-39,742,500	-1,987,125	0	0	0	0	0	0	0.00	0.00
2061	41	0.00%	0.00%	0	0	-39,742,500	-1,987,125	0	0	0	0	0	0	0.00	0.00
2062	42	0.00%	0.00%	0	0	-39,742,500	-1,987,125	0	0	0	0	0	0	0.00	0.00
2063	43	0.00%	0.00%	0	0	-39,742,500	-1,987,125	0	0	0	0	0	0	0.00	0.00
2064	44	0.00%	0.00%	0	0	-39,742,500	-1,987,125	0	0	0	0	0	0	0.00	0.00
2065	45	0.00%	0.00%	0	0	-39,742,500	-1,987,125	0	0	0	0	0	0	0.00	0.00
2066	46	0.00%	0.00%	0	0	-39,742,500	-1,987,125	0	0	0	0	0	0	0.00	0.00
2067	47	0.00%	0.00%	0	0	-39,742,500	-1,987,125	0	0	0	0	0	0	0.00	0.00
2068	48	0.00%	0.00%	0	0	-39,742,500	-1,987,125	0	0	0	0	0	0	0.00	0.00
2069	49	0.00%	0.00%	0	0	-39,742,500	-1,987,125	0	0	0	0	0	0	0.00	0.00
2070	50	0.00%	0.00%	0	0	-39,742,500	-1,987,125	0	0	0	0	0	0	0.00	0.00
Summation		100%	100%	113,928,500	455,714,000	1,727,487,611	86,374,381	396,675,000	10,164,201,923	7,045,008,990	1,815,140,635	168,414,832	1,836,123,615	1.27	0.13

1. ICIS, POLYETHYLENE US MARGIN REPORT, ICIS Weekly Margin - POLYETHYLENE (PE) US Methodology, pp.3

2. ICIS, ICIS Weekly Margin – PP US report. POLYPROPYLENE US MARGIN REPORT, pp.2 to pp.4

3. A M Saravanan, Khalid Ali Sulaiman, 2014, A Study on the Process Plant Design for Production of Polypropylene Plant, International Journal of Emerging Tec hnology and Advanced Engineering, pp.633

4. James G. Speight, 2002, CHEMICAL AND PROCESS DESIGN HANDBOOK, ISBN 0-07-137433-7, pp. 1.41 to pp.1.42 and pp.2.434 to pp. 2.437

PFD FOR PDH-PP CHEMICAL PLANT

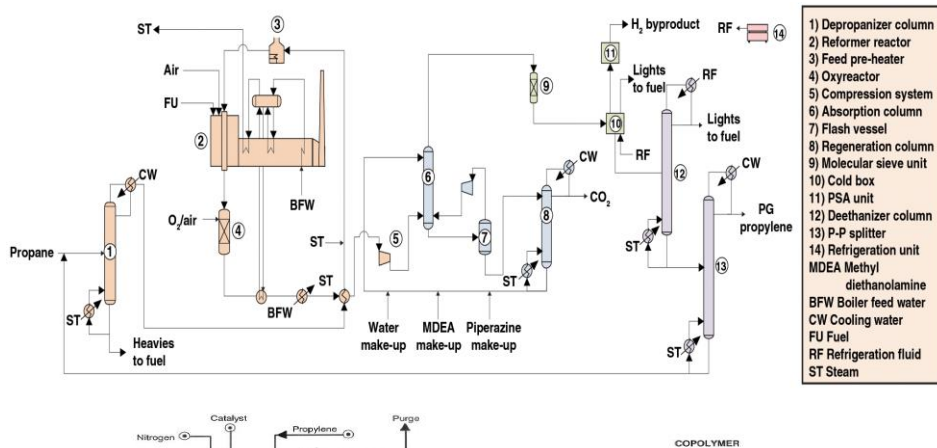

PFD FOR PDH

PFD FOR PP

